

# DUCTILE IRON HEAVY DUTY INSPECTION COVER & FRAME

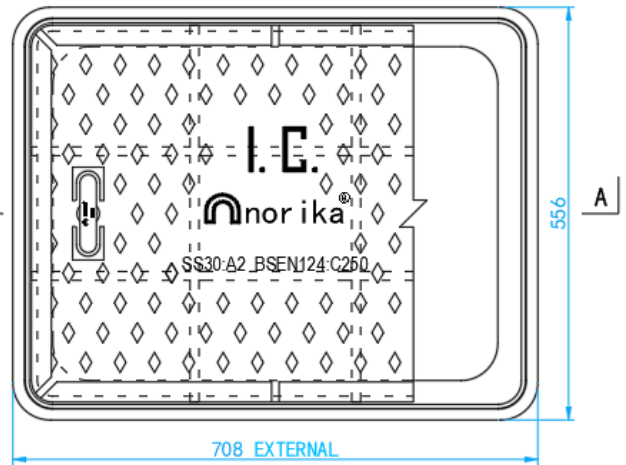

COMPLY WITH SS EN 124-2:2021  
SS 30:1999 [2012]

Type of Weight (Symbol)	SS 30	Design Load	Place of Installation	SS EN 124-2	Design Load
	A2	230KN	In carriageways not exceeding 0.5m away from kerb side channels of all roads and in carriageways of minor residential roads.	C250	250KN

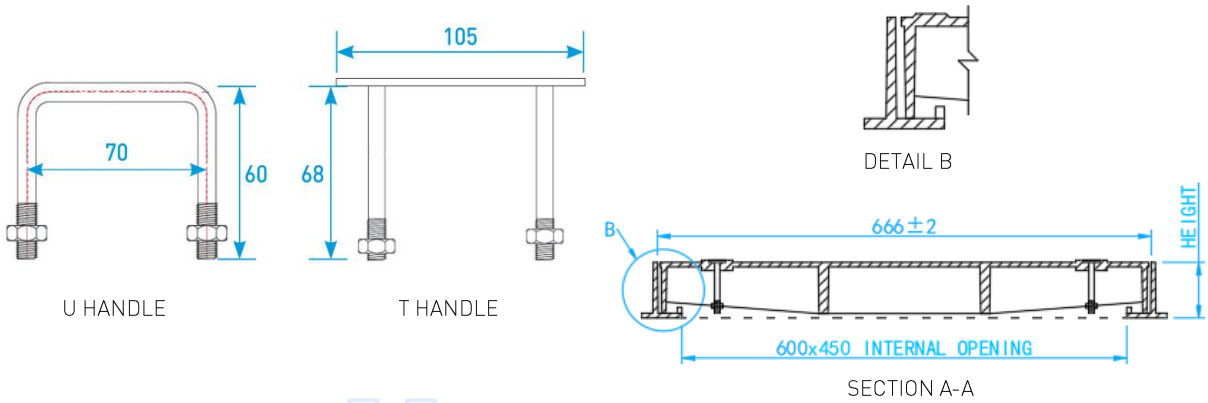

TOP VIEW

## DIMENSIONS

SKU	MATERIAL	INTERNAL OPENING (mm)	EXTERNAL (mm)	HEIGHT (mm)	Remarks / Optional
DIICCS-A2	Ductile Iron	600 X 450	708 X 556	75	"T" Or "U" Handle

\* Please specify 'T' handle or 'U' handle, upon placing order.