

REVERSIBLE GREASE TRAP FRAME & COVER 1800 (CHEQUERED SIDE)

COMPLY WITH GENERAL REQUIREMENTS OF
PUB/WRN/STD/040

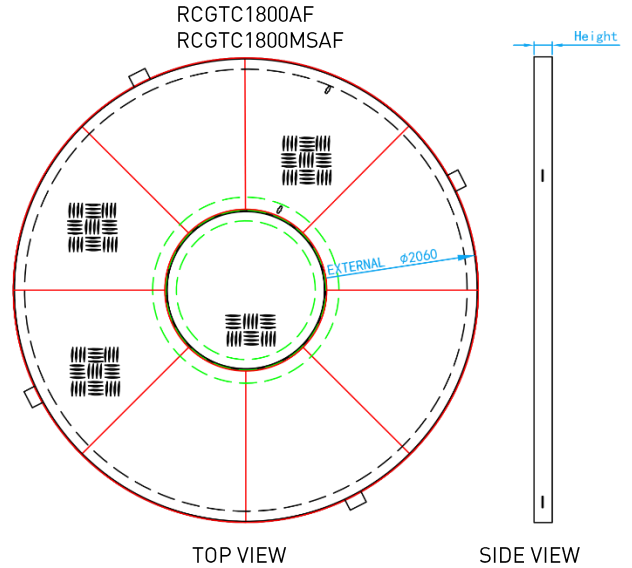

RCGTC1050ASG

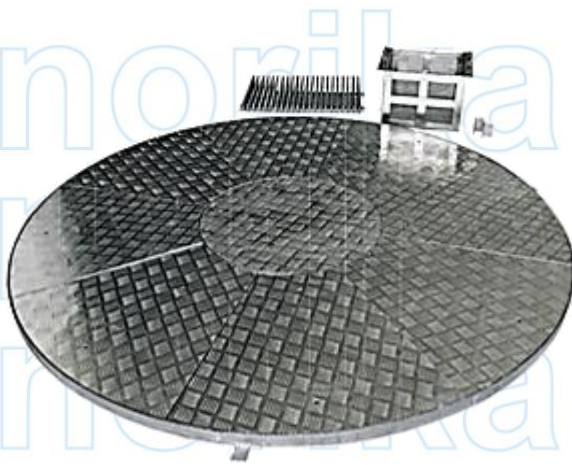
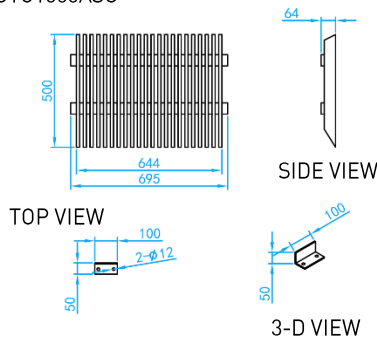

RCGTC1800ASB

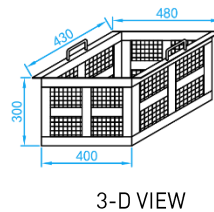

*** Available for aluminium and mild steel material**

COMPONENT ITEMS FOR FULL SET

NO	STOCK CODE
1	RCGTC1800AF / RCGTC1800MSAF
2	RCGTC150ASG
3	RCGTC1800ASB

DIMENSIONS

SKU	MATERIAL	EXTERNAL[mm]	HEIGHT [mm]	WEIGHT [kg]
RCGTC1800	Aluminium	Ø2060	50	140
RCGTC1800MS	Mild-Steel	Ø2060	50	250