

# HEAVY DUTY DUCTILE IRON FLEXIBLE COUPLING C/W EPOXY COATED

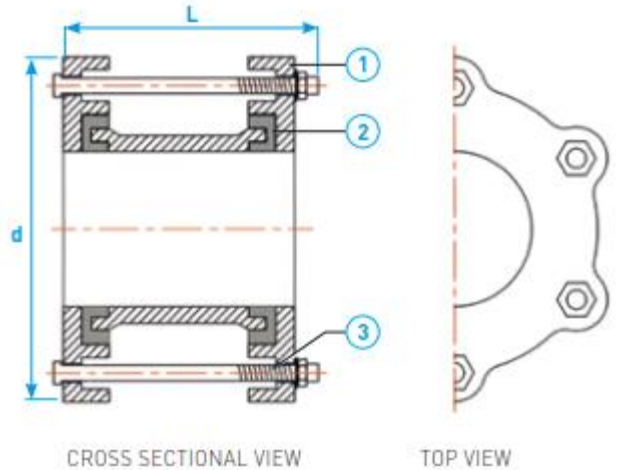
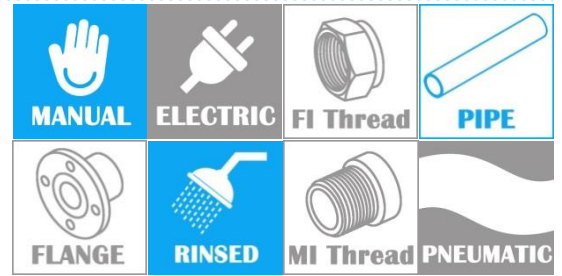

OPERATING PRESSURE	
Nominal Pressure	PN16
Sealing Test Pressure	1.76Mpa
Strength Test Pressure	2.4Mpa

COMPONENT PARTS		
ITEM	PARTS	MATERIAL
1.	Body	Ductile Iron
2.	Seal Ring	EPDM
3.	Bolt	Galvanized Iron

STANDARD SPECIFICATIONS						
SKU	SIZE (mm)	OD (mm)	d (mm)	L (mm)	NO OF BOLT	WEIGHT (kg)
DIFC080EPC	80	98	200	110	4	4.5
DIFC100EPC	100	118	220	110	4	5.2
DIFC150EPC	150	170	285	120	4	8.6
DIFC200EPC	200	222	340	120	4	11.5
DIFC250EPC	250	274	400	130	6	16.5
DIFC300EPC	300	326	455	130	6	17.8